

OWNERS MANUAL

ASSEMBLY • OPERATING • MAINTENANCE • REPAIR

KWIK-WAY

HYDRAULIC LOADER ATTACHMENT

LOADER MODEL NO. 45-08211

FOR

TORO WHEEL HORSE TRACTORS

Record and Retain the
MODEL and SERIAL Numbers
of your
KWIK-WAY LOADER

MODEL

SERIAL NUMBER

HYDRAULIC LOADER AND ATTACHMENTS
MANUFACTURED BY

K-W MANUFACTURING COMPANY, INC.

800 SOUTH MARION ROAD
SIOUX FALLS, SOUTH DAKOTA 57106
TELEPHONE (605) 336-6032
WATS (800) 843-3720

FRONT LOADER SAFETY RULES

OPERATING THE TRACTOR AND FRONT LOADER REQUIRES SPECIAL EFFORTS ON YOUR PART TO ENSURE YOUR SAFETY AND THE SAFETY OF OTHERS. KNOW THESE REQUIREMENTS BEFORE YOU OPERATE THE TRACTOR AND FRONT LOADER.

- To avoid severe personal injury or equipment damage, observe the following precautions.
 - All parts, especially guards and shields, must be in good condition, and securely in place.
 - Be sure all nuts, bolts, and etc. are tight.
 - Do not remove any guards, warning labels, shields or safety devices: They are installed for your safety.
- Know how to stop the engine quickly. Thoroughly understand operation of all the controls.
- Never allow anyone to operate the tractor and front loader without proper instructions.
- Do not allow passengers to ride on the tractor or front loader.
- Keep children and pets at a safe distance during operation.
- Never allow anyone to get under the loader bucket or reach through the lift arms when the bucket is raised or tractor engine is running.
- Always wear sturdy shoes or boots and avoid wearing bulky or loose fitting clothing while operating the tractor and front loader.
- Be alert. Do not operate the front loader when tired, ill or under the influence of alcohol or drugs.
- Work with equipment only in daylight or good artificial light.
- Watch out for and avoid rocks, roots, holes and other hidden objects.
- If you hit an object, stop and inspect for damage, repair any damage before continuing to operate the tractor and loader.
- Replace damaged, worn or broken parts immediately.
- The exhaust contains poisonous carbon monoxide gas that can cause loss of consciousness and may lead to death, if the tractor and loader is operated in an enclosed area.
- Before leaving the tractor unattended, always lower the loader bucket to the ground, shift the transmission to neutral, set the parking brake, stop the engine and remove the ignition key to prevent children or unauthorized persons from starting the engine.
- Prolonged exposure to loud noise can cause permanent loss of hearing. Wear suitable protective device such as ear plugs to protect against loud or objectionable noise.
- Use extreme caution when crossing a drive, walkway, or road. Stay alert for hazards of traffic.
- The use of heavy equipment and/or lifting excessive loads may adversely affect tractor stability and control.
 - Use only recommended tractor hitch attachment points.
 - Limit loads to those within the tractor and front loader limitations as stated in this manual.
 - Use caution while turning or backing up, and when operating on uneven terrain.
 - Do not operate without rear wt. box mounted to tractor rear hitch and filled with sand or equivalent.
- Before installing or using the front loader, carefully read all instructions and precautions.
- Make sure the tractor transmission lever is in "neutral" before starting the engine.
- Operate the tractor and front loader at slow speeds until you become familiar with all the operating characteristics and controls.
- Do not operate the tractor and loader until you are sure the area is clear of people and pets.
- Sudden stops of the tractor and loader during operation can cause the tractor to overturn. Be especially careful during sharp turns and when the bucket has material in it.
- Carry the loader arms and bucket as low as possible during transport. This will enhance tractor and loader stability and front vision.
- Using the front loader for handling large objects such as logs or oil drums is not recommended. Such items can easily shift or roll down the loader front arms causing equipment damage or severe personal injury.
- Never operate the tractor and front loader when visibility is diminished by darkness or bad weather.
- Avoid loose fill, rocks and holes. They may cause tractor instability or cause the tractor to overturn.

- The front loader is intended for use on relatively flat terrain.
- Avoid overhead wires and obstacles when the loader is in the raised position. Contact with electric wires can cause electrocution.
- Allow for the added length of the front loader when making turns to prevent striking people or objects.
- When operating the front loader on a slope, always drive up and down the face of the grade. Turning or driving across the face of the slope may cause the tractor to overturn.
- Operate the front loader arms gradually by "feathering" the loader controls to prevent abrupt movements that could cause damage to the tractor and front loader.
- Use added caution when working with shifting or loose loads in the bucket. It could cause tractor instability or fall out of the bucket and cause personal injury.
- Attempting to change gears while operating on a slope may adversely affect tractor stability and control and severe personal injury could result.
- Do not back down or rapidly accelerate up a sloping surface.
- To avoid loss of control or overturning, do not stop or turn on sloping surfaces.
- Do not operate the loader near the edge of a ditch or embankment. Slipping off the edge could lead to severe personal injury or equipment damage.
- When descending a slope, disengaging the clutch or shifting to neutral can cause loss of control and may result in severe personal injury.
- To avoid injury to yourself and others, always do the following before leaving the tractor and front loader unattended:
 - Park on level ground and lock the parking brake.
 - Lower the bucket to the ground.
 - Stop the engine and remove the ignition key.
- If it becomes necessary to park on a slope, be sure to lock the parking brake and securely block the wheels.



LOOK FOR THIS SYMBOL TO POINT OUT IMPORTANT SAFETY PRECAUTIONS. IT MEANS—ATTENTION!!! BECOME ALERT!!! YOUR SAFETY IS INVOLVED.

CONGRATULATIONS on your purchase of a TORO WHEEL HORSE Hydraulic Loader. It has been designed, engineered and manufactured to give you the best possible dependability and performance.

Should you experience any problem you cannot easily remedy, please contact your nearest Dealer. They have competent, well trained technicians and proper tools to service or repair this unit.

Please read and retain this manual. The instructions will enable you to assemble and maintain your loader properly. Always observe the "SAFETY RULES".

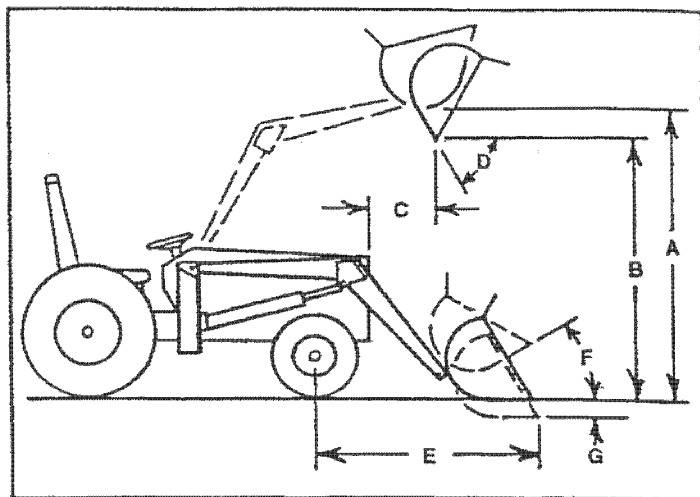

LOADER SPECIFICATIONS

RATED LIFT CAPACITY	350 lbs.
BUCKET SIZE (WIDTH)	40 in.
HYDRAULIC CYLINDERS	2 in. D/A
COUNTER WEIGHT	Min. 280 lbs. required. Use the optional weight box, or equivalent.
SUBFRAME	Frame Mounted to tractor.
HYDRAULIC PUMP DRIVE	Engine Belt Driven
MAXIMUM LIFT HEIGHT	"A" 76 in.
CLEARANCE W/BUCKET DUMPED	"B" 55 in.
REACH @ MAXIMUM HEIGHT	"C" 20 in.
MAXIMUM DUMP ANGLE	"D" 47°
REACH W/BUCKET ON GROUND	"E" 43 in.
BUCKET ROLL BACK ANGLE	"F" 12°
DIGGING DEPTH BELOW GRADE	"G" 3 in.

MODEL NUMBER: 45-08211

SERIAL NUMBER: _____

DATE OF PURCHASE: _____

THE MODEL AND SERIAL NUMBERS WILL BE FOUND ON A DECAL ATTACHED TO THE FRONT OF THE R.H. LOADER UPRIGHT.

YOU SHOULD RECORD BOTH SERIAL NUMBER AND DATE OF PURCHASE AND KEEP IN A SAFE PLACE FOR FUTURE REFERENCE.

CUSTOMER RESPONSIBILITIES

- Read and observe the safety rules.
- Follow a regular schedule in maintaining, caring for and using your loader.
- Follow the instructions of this Owner's Manual.

Limited Warranty

All K-W PRODUCTS have been manufactured from the very finest materials and by skilled workmen, therefore, K-W Manufacturing Co., Inc. guarantees PRODUCTS against defective workmanship and materials for a period of one year from the date of purchase.

This warranty is not a service guarantee, nor is it any assurance that the product is perfectly designed or perfectly built; neither is it an expression of any belief that the product cannot be improved. Further, this warranty is not a guarantee against hazards such as wear, tear, misuse or misfortune nor against problems arising from incorrect set-up or servicing and is not a guarantee that the performance will meet the expectations of the purchaser.

This warranty is void should the product be repaired or modified in any way not authorized by K-W Manufacturing Company.

There is no other express warranty. Implied warranties, including those of merchantability and fitness for a particular purpose other than the extent permitted by law any and all implied warranties are excluded. This is the exclusive remedy, and liability for consequential damages under any and all warranties are excluded to the extent exclusion is permitted by law.

Components such as pumps, winches, hoses, etc., will carry only their respective manufacturer's warranty. This warranty does not cover any merchandise which, in the opinion of the company, has been subject to negligent handling, misuse, or accident.

Warranty claims on components will not be approved and credit issued until defective items are returned to the factory (PREPAID) and our respective suppliers have approved our Warranty Claims. When credit is received by K-W Manufacturing Co., Inc., we will issue credit in an amount equal to that received from the component supplier. K-W cannot warrant any merchandise, which, in the opinion of the company, has been subjected to negligent handling, misuse, or accident. All Warranty Claims must be submitted in writing. Written approval from the company must be obtained before any merchandise and warranty parts are returned to the factory.

K-W Manufacturing Company, Inc., reserves the right to make changes, improvements, and modifications at any time without incurring the obligation to make such changes, improvements, and modifications on any products sold previously.

K-W MANUFACTURING COMPANY, INC.

800 South Marion Road
Sioux Falls, South Dakota 57106
Phone: 605/336-6032

LOADER REMOVAL FROM CRATE

- Remove the top of the crate.
- Remove the sides of the crate.
- Inspect the loader for shipping damage.
- Remove the loader from the base of the crate.
- Remove the parts from the parts box and check that you have received all the parts and pieces for the loader.

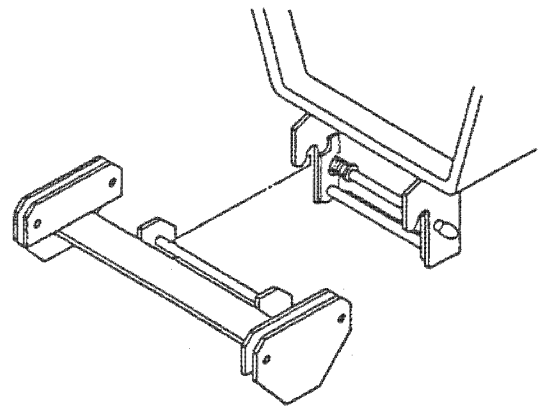

FIG. 1

ASSEMBLY

IMPORTANT: Read these instructions completely BEFORE doing anything. Then go back and begin step by step.

When R.H. (right hand) and L.H. (left hand) are used, it means from behind the tractor and facing the loader.

NOTE: Leave all nuts and bolts finger tight until tightening is specified. This is important for ease of assembly.

TOOLS NEEDED TO MOUNT LOADER

1. Open end and box end wrench set
2. Hammer
3. Pliers
4. Drift punch — used to align holes

Attach the Brace Arm Mount

The brace arm mount is attached to the quick attach bracket at the front of the tractor frame as shown in FIG. 1.

Assemble and Mount the Loader Sub-Frame

The sub-frame and rear axle brackets can be assembled to fit the C-195, 8 speeds and hydrostatic drive models. See FIG. 2 for the proper assembly to fit any of the three tractors.

Secure the rear axle brackets to the sub-frame with (2) $\frac{1}{2}$ — 13 x $1\frac{1}{2}$ hex hd. capscrews, nuts and lockwashers on both sides.

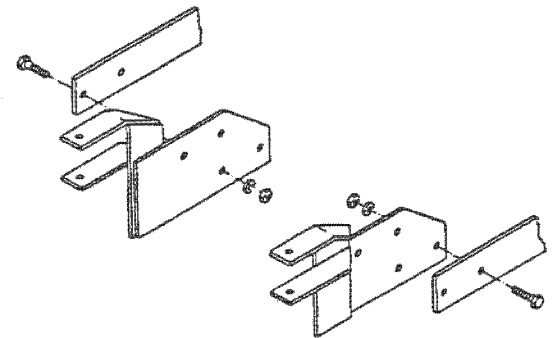

C-195

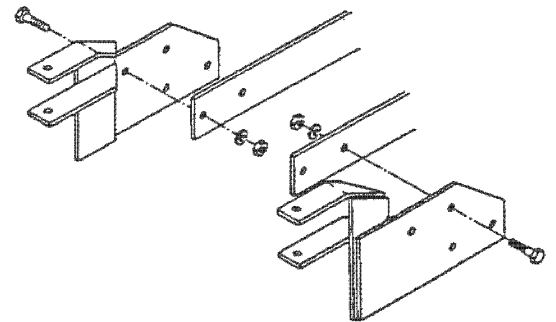

8 SPEED TRANSMISSION

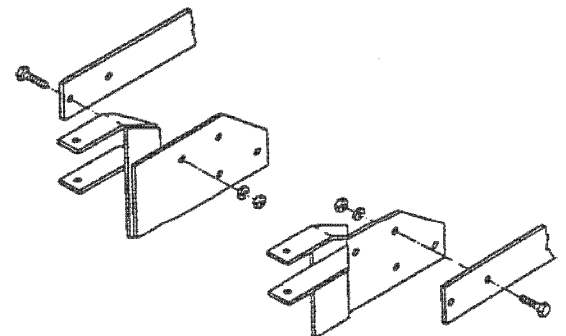

HYDROSTATIC TRANSMISSION

FIG. 2

MOUNTING THE LOADER UPRIGHTS AND MAIN-FRAME ASSEMBLY

NOTE: The uprights and the mainframe come assembled. All cylinders and hoses have been attached to the mainframe except the two hoses attached to the pump.

- Set the loader mainframe assembly on its stands and move the tractor carefully between the uprights.
- Move the tractor forward until the uprights are positioned over the upright pads on the sub-frame. Use two people to lower the uprights onto the pads and secure both sides in the locked position with a 1/2 x 4 1/4 clevis pin and #3 clip pin (See Fig. 6).

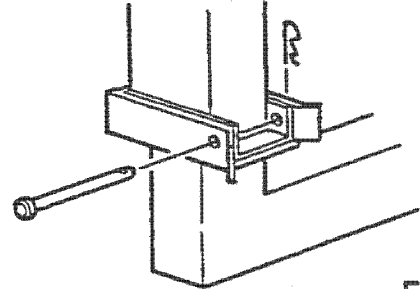
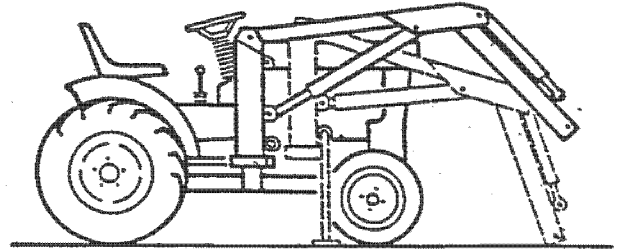

FIG. 6

- Attach brace arms to the uprights using a 1/2 -13 x 1 1/2 hex hd capscrew, nut and lockwasher on both sides.
- Attach brace arms to the front mount using a 1/2 x 1 1/4 clevis pin and #3 clip pin on both sides (See Fig. 7).
- Tighten all capscrews securely.
- Use the holes to the rear of the brace arm mount when mounting the loader on the C-195 tractors. Use the holes to the front of the brace arm mount when mounting the loader on all other tractors.

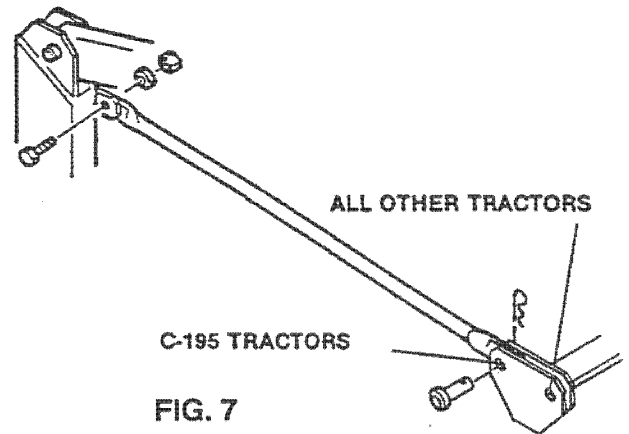

FIG. 7

CONNECTING PRESSURE AND SUCTION HYDRAULIC HOSES

- The pressure and suction hose have been attached to the pump. Route the two hoses along the brace arm on the left side of the tractor and toward the reservoir upright.
- Slide the suction hose (large hose) over the fitting at the bottom of the reservoir and secure with a hose clamp.
- Screw the pressure hose (small hose) into the open port on the R. H. underside of the valve. Tighten securely (See Fig. 8).
- Secure the hoses to the brace arm with nylon tie straps. Do not let the hoses hang, and route the hoses so that they will not come in contact with the front tire.

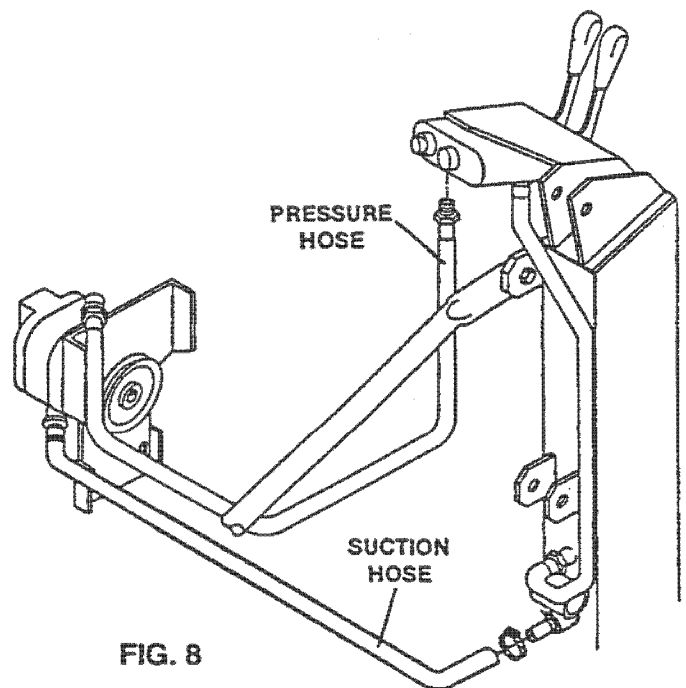

FIG. 8

ATTACH VALVE HANDLES

- Install the valve handles to the hydraulic control valve mounted on the left upright. First attach the offset "B" handle to the spool used for bucket operation. Attach the straight "A" handle to the spool used for loader operation. (See Fig. 9).

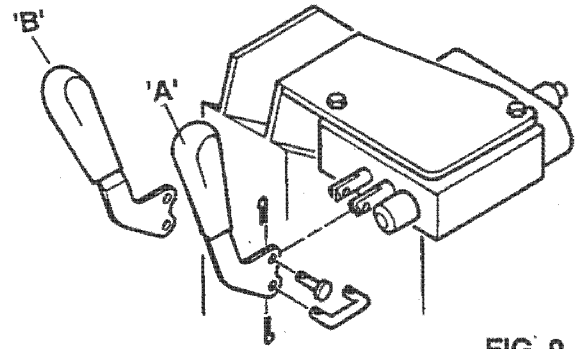

FIG. 9

ATTACHING THE BUCKET

- Using the bottom holes on the bucket, attach both sides of the bucket to the loader frame. Use two 3/4 x 3 clevis pins and #11 clip pins.
- Attach both cylinders to top holes on bucket. Use two 3/4 x 3 clevis pins and #11 clip pin. (See Fig. 10).

The loader is now ready for hydraulic fluid.

HYDRAULIC FLUID SERVICING

You will need 6 1/2 quarts of a good grade hydraulic oil or ATF (Dexron) automatic transmission fluid.

- Remove filler plug and oil check screw on back of left upright. Fill with 4 quarts of hydraulic oil.
- Start tractor engine and set speed at 1/2 throttle and operate loader lift and bucket cylinders at least five or six times to purge the system of air. Lower the loader bucket to the ground. **NOTE: Do not push handle "A" all the way forward into float position.**
- Retract bucket cylinders by pulling back on handle "B".
- Add 2 1/2 more quarts of hydraulic oil or until oil runs out the check hole. Replace oil fill plug and oil check screw. (See Fig. 11).

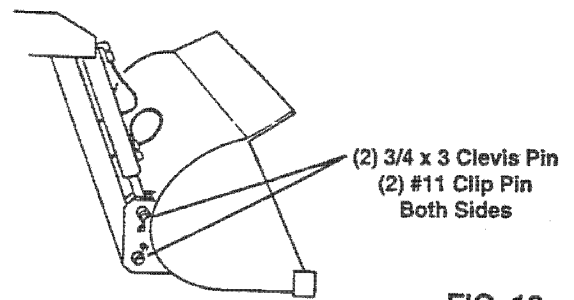

FIG. 10

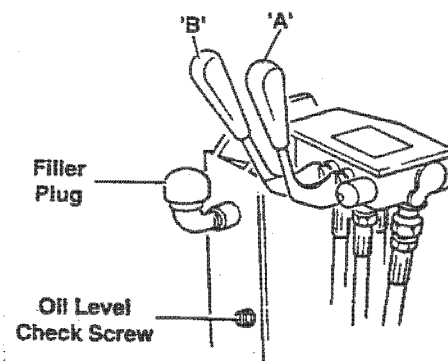

FIG. 11

OPERATIONAL CHECK

Check all pivot points on the loader. Lubricate as necessary. (See lubrication chart on page 17.)

Check loader hydraulic fluid.

NOTE: Check fluid level with loader arms down and bucket flat on the ground.

Remove oil check screw and see if oil will run out hole. (Do not overfill.)

If oil level is low, remove oil fill plug and add hydraulic fluid until it runs out of oil check hole.

Re-install and tighten the oil check screw and oil fill plug. Operate the loader up and down several times and re-check oil level. Replenish if necessary.

Operate and check the loader main frame and bucket for interference, noise, and bending of parts.

CAUTION –Before using loader, double check.

- Tractor Owner's Manual for recommended tire pressure.
- That all bolts and hoses have been tightened and that all tools have been removed from tractor and loader.
- Weight box is installed and correct weight added.
- Make sure the rear wheels of the tractor are mounted to the rear axle in the position that will provide the widest tread width.

START UP PROCEDURE

Check front loader hydraulic fluid level. (page 10)

NOTE: Bucket and lift cylinders should be fully retracted when checking hydraulic fluid level.

Check all hydraulic hose connections to ensure that they are not leaking.

Lubricate all pivot points that incorporate grease fittings.

Start tractor and run engine at approximately 1200-1400 RPM for initial cycling of loader.

WARNING –Before using front loader for the first time, cycle lift and bucket cylinders to purge air from cylinder. Air in the hydraulic system can cause unexpected fall of mainframe, causing injury or damage to loader or tractor.

Cycle lift and bucket cylinders with bucket empty several times to seat-in cylinder components.

Check all hydraulic hose routings to ensure adequate clearances exist between hoses and adjacent components.

WARNING –The tractor/front loader should only be operated with all safety equipment properly installed.

CAUTION –Operate loader from the tractor seat only.

OPERATING TIPS

NOTICE –Do not use the bucket for pushing down material with bucket cylinders partially extended. Cylinder and rod may be damaged.

Do not tip bucket cutting edge down (fully extend bucket cylinders) during backfilling/backgrading operation. Cylinder and rod may be damaged.

Position vehicles to be loaded as near the pile as possible and in such a direction as to minimize the amount of tractor turning required to dump.

Do not use spill guard to push objects as it will deform and become damaged.

Keep the unit clean and perform regular service. Observe safety instructions whenever cleaning, servicing, or lubricating.

We urge you to follow this advice:

1. Read and understand this manual as well as the tractor owner's manual.
2. Remember and observe the Safety Precautions brought to your attention in this manual, the tractor manual and on the loader itself.
3. Use good common sense in the everyday operation of this unit. Safety instructions can never be all inclusive. You are responsible for watching out for, and avoiding unsafe conditions.
4. Never exceed the limits of a piece of machinery. If its ability to do a job or to do so safely is in question -**Don't try it.**
5. Don't hurry the learning process or take the unit for granted. Ease into it and become familiar with your new loader and tractor.
6. When lowering a heavy load, ease it downward slowly. Never drop a loaded bucket and "catch" hydraulically. Stopping a load after it has gained downward momentum places undue strain on the unit and may cause damage to the loader or tractor.

WARNING –Before disconnecting hydraulic lines, relieve all hydraulic pressure. Escaping hydraulic oil under pressure can have sufficient force to penetrate the skin causing serious personal injury. If injured by escaping hydraulic oil, consult a physician immediately.

⚠ WARNING –Do not operate the loader if the hydraulic fittings or hoses are leaking or damaged. A sudden line burst can cause the main frame to drop suddenly, causing damage to the tractor or loader or injury to personnel.

BEFORE OPERATING, LUBRICATE ALL MOVING PARTS. (REFER TO LUBRICATION SECTION)

COLD WEATHER OPERATION

To assure smooth operation in cold weather, allow the tractor to warm up. Slowly cycle the loader and bucket several times to warm the fluid in the hydraulic fluid system. The loader may operate erratically until the hydraulic fluid has warmed to operating temperatures.

OPERATING INSTRUCTIONS

Main, lift and bucket cylinders are double acting type (both push and pull under hydraulic power). This means that the loader can be forced down as well as up. It means that the bucket can be tilted down or up with hydraulic pressure.

HYDRAULIC CONTROL VALVE

Your loader control valve has two handles. The right handle operates the lift cylinders (the loader) and has a float position. The left handle operates the bucket cylinders. Both handles will return to neutral except from float position when released.

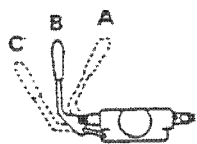

LEFT HANDLE – BUCKET

- A – Bucket Dump
- B – Neutral
- C – Bucket Back

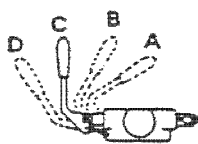

RIGHT HANDLE – LOADER

- A – Float Position
- B – Loader Down
- C – Neutral
- D – Loader Up

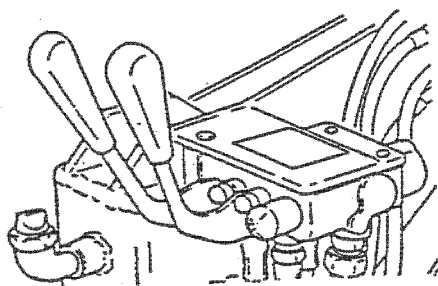

HANDLE USE

BUCKET

POSITION A - Left handle pushed forward, bucket will dump.

POSITION B - Neutral position

POSITION C - Left handle pulled back, bucket will roll back.

LOADER

POSITION A-Right handle pushed all the way forward (this is float position). Handle will stay until pulled back.

POSITION B-Right handle pushed half way forward, bucket will lower.

POSITION C-Neutral position.

POSITION D-Right handle pulled back, bucket will raise.

NOTE: In float position there is no hydraulic pressure going to the lift cylinders. If the loader frame is up off the ground, it will lower to the ground by gravity. When the bucket is on the ground (and the valve is still in float) the bucket will follow the shape of the ground even when the tractor is moving. This allows hydraulic oil to flow back and forth in the hydraulic system as the loader is raised and lowered by the ground contour.

⚠ CAUTION –Do not allow bucket lip to dig into ground when tractor is moving forward in float. The bucket bottom should be level with the ground or slightly rolled back.

The float position is most commonly used with attachments in snow removal. Tractor should be run at slow ground speed and the lift and bucket cylinders used to work material loose and fill the bucket.

CONTROLLED RATE OF LOADER FUNCTIONS

By feathering (slightly moving) the control levers, precise operational speeds can be obtained. This action controls the position of the valve spools in the control valve and regulates flow of oil from/to cylinders.

It is important to utilize this operational practice when lowering the main frame when the bucket is loaded with material.

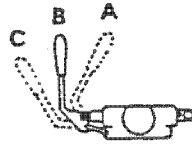

LEFT HANDLE - BUCKET

- A - Bucket Dump
- B - Neutral
- C - Bucket Back

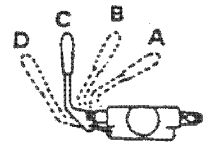

RIGHT HANDLE - LOADER

- A - Float Position
- B - Loader Down
- C - Neutral
- D - Loader Up

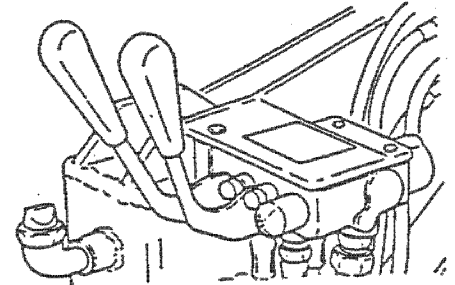

SCRAPING

When scraping, the "float" position should be utilized to maintain the bucket firmly on the ground and at the same time allow the bucket to follow ground contours.

The bucket should be positioned level to the ground during "scraping" operations.

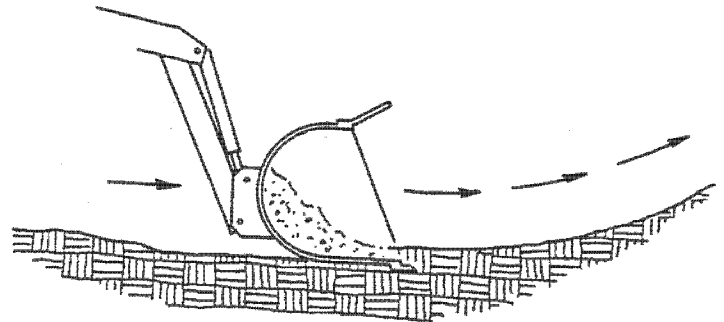

BACKFILLING/BACKGRADING

When "backfilling" or "backgrading", position the bucket so it is level on the ground. Do not dump material from the bucket. Additional weight of material in bucket will assist in "backgrading" and increases loader efficiency during "backfilling".

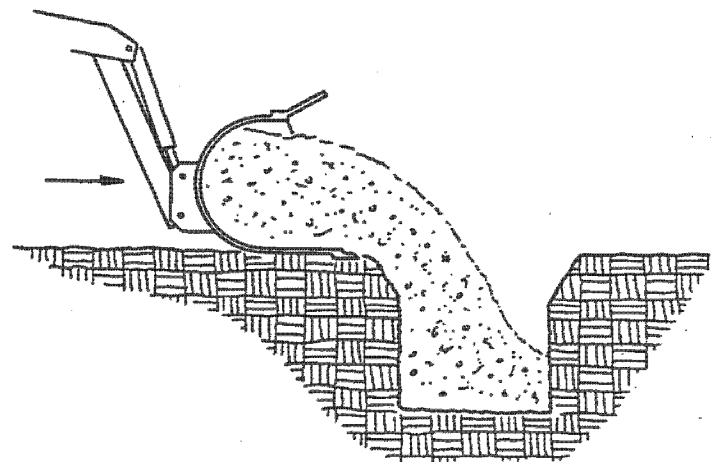

LOADING

Drive straight ahead into pile with bucket cutting edge level with the ground. In order to prevent possibility of damaging tractor or loader:

- Do not ram into pile at high speed.
- Do not attempt to turn tractor while loading.

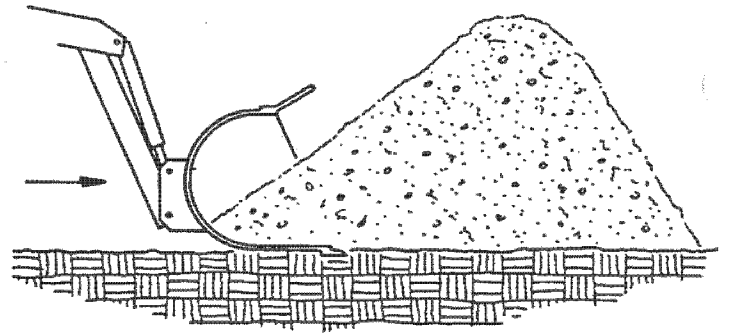

As bucket begins to fill with material, gradually roll the bucket back and raise the loader to increase "fill" capacity. This procedure also results in the material being removed in layers from the top for maximum loading efficiency.

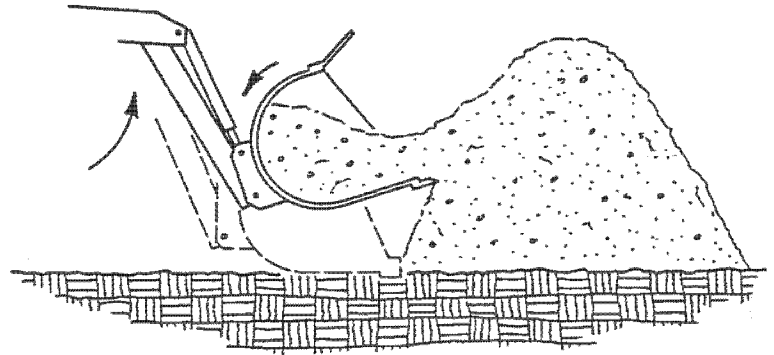

When the bucket is full, raise loader so that the bucket is clear of material and slowly back out of pile.

For maximum loading efficiency, minimize angle of turn and distance between the loading and unloading points.

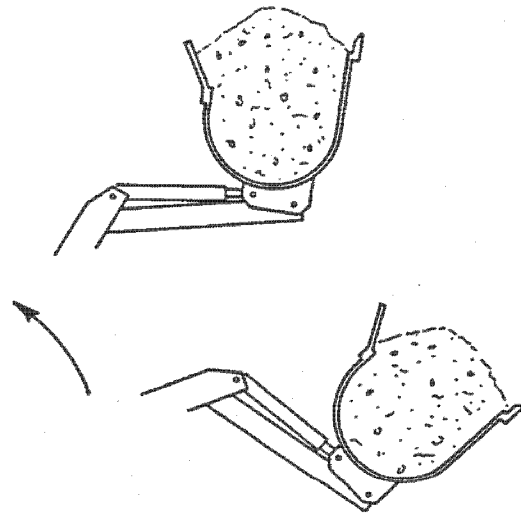

TRANSPORTING MATERIAL

Transport material to "unloading point" with loader bucket as low as possible to prevent spillage and maintain maximum tractor/loader stability.

NOTICE –During transport the loader should be in a position that will not impair operator's vision.

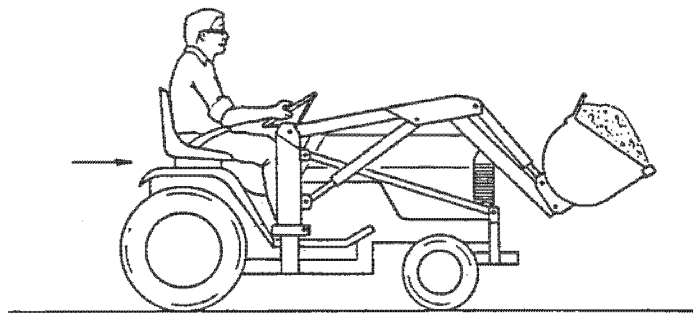

Observe the following safety messages:

⚠ DANGER –Avoid any overhead wires or obstacles when loader is raised, to avoid damage or possible death by electrocution.

⚠ WARNING –A loaded bucket should be transported in a low position at slow ground speeds, especially if the ground is irregular. Make turns slowly and use the tractor brakes cautiously. A full bucket in the raised position alters the center of gravity of the unit and increases the possibility of mishaps.

⚠ WARNING –Do not lift or carry personnel on a loader or attachment; a slip or fall could cause serious injury.

UNLOADING

As the tractor approaches the "unloading point", raise the loader to the height required for clearance to "dump" bucket.

Drive slowly to position bucket above "unloading point", stop tractor and dump bucket.

For best stability, do not raise loader higher than required for "dumping" clearance.

As "dumping" clearance height increases, the bucket position must be adjusted to maintain a level bucket to prevent excessive spillage of material from bucket.

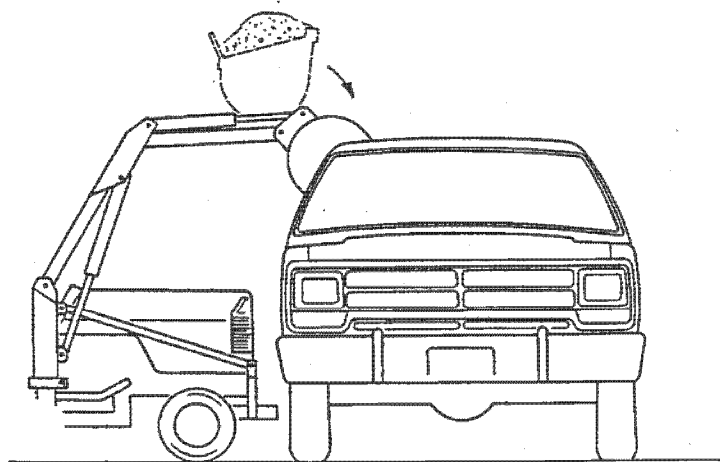

LUBRICATION AND MAINTENANCE

Do not perform any service/maintenance operations with front loader raised off the ground.

Lower front loader to the ground and relieve pressure in loader hydraulic lines prior to performing any service/maintenance operations on tractor or loader.

⚠ DANGER –Keep hands and body from pressurized lines. Use paper or cardboard, not body parts, to check for leaks. Hydraulic oil under pressure will penetrate the skin causing serious injury.

Make sure that all operating and service personnel know that in the event hydraulic fluid penetrates the skin, it must be surgically removed within a few hours by a doctor familiar with this form of injury, or gangrene may result.

⚠ WARNING –Do not operate the front loader if the fittings or the hoses are leaking or damaged. A sudden line burst could cause the main frame to drop suddenly, causing damage to the tractor or loader or injury to personnel.

⚠ WARNING –Accidental movement of control lever or leak in the hydraulic system could cause main frame to drop, causing serious injury. Do not stand on walk under a raised attachment.

When checking hydraulic system oil level, the loader should be on the ground and bucket fully retracted (all cylinders in the retracted position). Grease all loader pivot points as indicated on lubrication chart.

Inspect hydraulic hoses, connections, control valve and cylinders for evidence of leakage.

If oil seepage past cylinder rod is evident, look for scoring on rod.

Tractor tire inflation should be checked as listed in tractor owner's manual to ensure tire inflation is to specification.

Unequal inflation can result in bucket not being level to the ground.

Front tires should be maintained at maximum recommended inflation to maintain normal tire profile with added loader weight and material.

LUBRICATION AND MAINTENANCE CHART

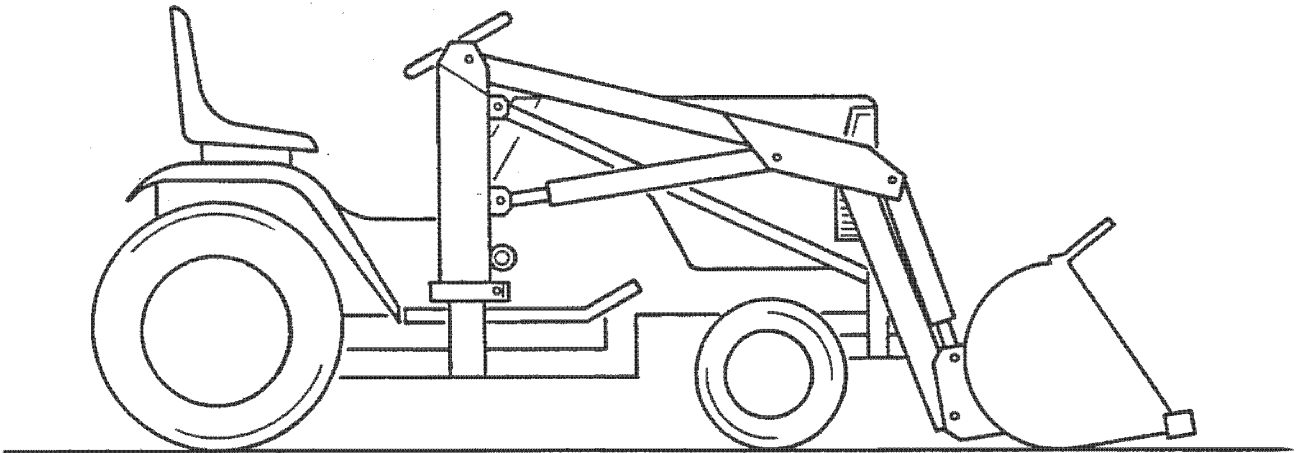

LUBRICATION AND MAINTENANCE CHART

Hydraulic oil level	Check	Daily/10 Hrs
Tire inflation	Check	Weekly/50 Hrs
Loader pivot points	Lubricate	Daily/10 Hrs
Hydraulic lines hoses and connections	Check for leakage wear and damage	Daily/10 Hrs
Lift and bucket cylinders	Check for seepage	Daily/10 Hrs
Mounting pins, Clip pins Fixing pins	Check,	Daily/10 Hrs replace if missing
Sub-frame mounting and hardware	Check	Weekly/50 Hrs Re-torque

IMPORTANT - BEFORE USING LOADER

DOUBLE CHECK:

- Tractor Owners Manual for recommended tire pressure.
- Check that all bolts have been tightened, that all hoses have been tightened and that all wrenches, etc. have been removed from tractor.
- Counter balance weight box, wheel weights, or fluid in tires.

BALLAST AND OTHER REQUIREMENTS:

C-85, C-105, C-125, C-145, C-165, C-175, GT-1800 and GT-1848,
400, 500 series: (with 40" bucket or 48" dozer)

- Chassis mount weight box filled with sand or gravel (44-01210). (230 lb.)
- Dual wheels
 - dual wheel adapters kit (80730)
 - 2 additional wheel & tire assemblies
- Heavy duty front spindle and wheel kit (8-0490) for C, GT series, (8-0493) for 400, 500 series.

C-195: (with 40" bucket or 48" dozer)

- Chassis mount weight box filled with sand or gravel (44-01210). (230 lb.)
- One pair rear wheel weights (8-1141).

C-195: (with 48" tine fork or 48" fork lift)

- Chassis mount weight box filled with sand or gravel (44-01210).
- Two pair rear wheel weights (8-1141).

LOADER REMOVAL FROM TRACTOR

- Select a level, safe, and solid place for loader removal.
- Place bucket flat on the ground or in a slightly rolled back position.
- Use the R.H. hydraulic control handle to apply a slight downward pressure on the bucket. This will relieve pressure on the two pins holding the brace arms to the front mount.
- Remove the #3 clip pins and 1/2 x 1 1/4 clevis pins which hold the brace arms to the front mount. (See Fig. 12).

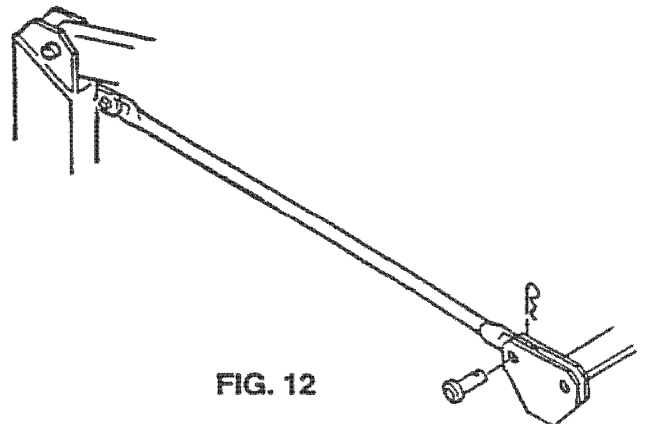

FIG. 12

LOADER REMOVAL FROM TRACTOR

- Release the downward pressure by pushing the R.H. control handle forward.
- Remove the two #3 clip pins and 1/2 x 4 1/4 clevis pins which hold the uprights to the sub-frame pads.
- Push forward the R.H. control handle to contract lift cylinders. The uprights will move forward and unlock from the sub-frame pads.
- Insert loader parking stands into the brackets on the loader uprights. Secure the stands to the uprights using the #3 clip pins removed from the 1/2" upright locking pins. (See Fig. 13).

NOTE: Double check to see that stands are secure and locked in proper position.

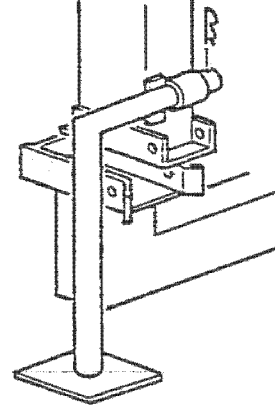
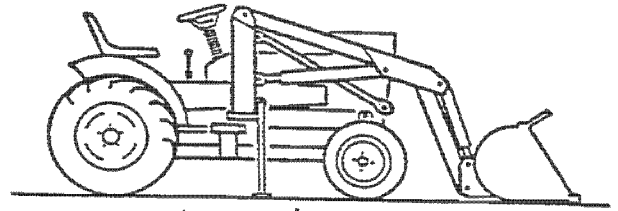

FIG. 13

- Turn off tractor engine and put tractor in neutral. Roll tractor back approximately 2 feet.
- Loosen the capscrews that secure the pump assembly to the pump mount plate on the sub-frame. Remove the pump assembly and place near the upright on the left side of the tractor. Leave the hoses connected. (See Fig. 14).
- Remove the belt from the engine pulley.

NOTE: Do not disconnect hoses.

- Loader is now parked and ready for storage.
- For front mount and sub-frame removal see mounting instructions on page 8.

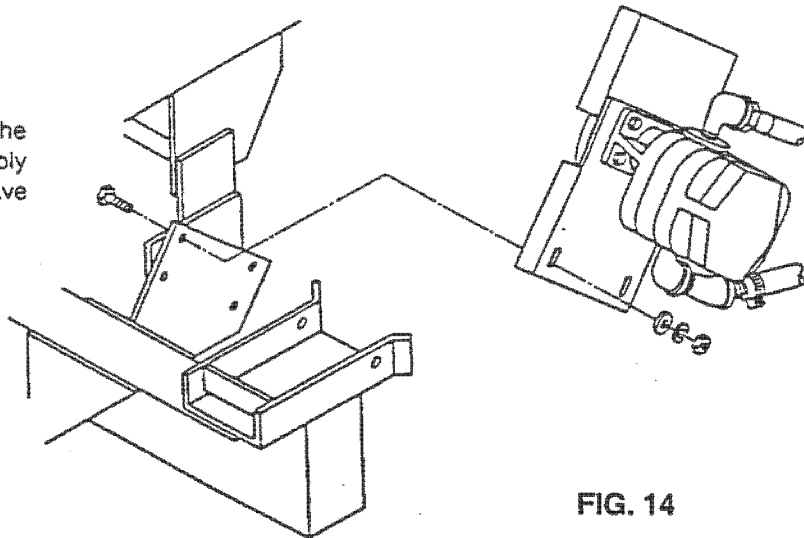

FIG. 14

STORAGE

END OF SEASON

- If loader is to be dismantled from the tractor during storage, make sure parking area is on hard, level ground.
- Store in a dry, sheltered area, if possible.

NOTE: All hydraulic cylinders should be in the retracted position.

- Thoroughly clean the loader of all accumulated dirt and oil.
- Completely lubricate the loader as specified in lubrication section of manual.
- Using an oil soaked cloth, lubricate all hydraulic cylinder rods to protect them from rust and corrosion.
- Repaint any areas where paint is worn or damaged.
- Wear areas on buckets or other attachments should be coated with grease to prevent rust or corrosion.
- Replace any safety or warning labels that are not readable due to wear or damage.

⚠ WARNING Do not allow children to play on or around the tractor or loader.

BEGINNING OF SEASON

- Review safety precautions and operation sections of manual.
- Thoroughly clean loader of all accumulated dirt and grease.
- If removed from tractor for storage, remount loader per "Loader Installation" section of this manual.
- Completely lubricate the loader per the "Lubrication" section of this manual.
- Clean with solvent any exposed surfaces which had been coated with grease. Wipe dry with a clean cloth, then lubricate with an oil soaked cloth.
- Tighten any bolts that may have been loosened and make sure all pins are in place.
- Start tractor and operate loader to make sure it is operating properly and all hoses are properly connected.
- Check hydraulic fluid level in loader mast and fill if required. Use oil recommended in this manual.
- Make sure hydraulic hoses, lines and fittings are in good shape and are not leaking. Repair or replace as needed.

TROUBLE SHOOTING

SYSTEM DOES NOT WORK AT ALL

No oil in system—Fill to proper level. Check system for leaks.

Oil low in reservoir—Check and fill to proper level. Check system for leaks.

Restriction in system—Oil suction line could be collapsing to cut off oil supply. Replace line.

Air leaks in pump suction line—Check hose clamps or replace hose.

Dirt in pump—Clean and repair pump. If needed, drain and flush hydraulic system.

Badly worn pump—Check for problems causing pump wear.

Oil leak in pressure lines—Tighten fittings or replace defective lines.

Hoses attached improperly—Attach properly and tighten securely.

Control Valve Defective—Replace

LOADER OPERATES WITH STOPS AND STARTS

Air in system—Examine suction side of system for leaks. Make sure oil level is correct. To get air out of system after oil level is correct and leaks fixed, use bucket and loader cylinders 5 to 6 times to purge the system of air.

Cold oil—Oil viscosity may be too high at start. Operate slowly to allow oil to warm up.

Components sticking or binding—Check for dirt or gummy deposits.

Pump damaged—Check for worn or broken parts.

SYSTEM RUNS OR WORKS SLOWLY

Cold oil—Allow to warm up before operating.

Oil viscosity too heavy—See specifications on proper oil.

Not enough engine speed—Increase engine speed.

Low oil supply—Check reservoir and add oil if needed. Check system for leaks that could cause low oil.

Air in system—Check suction side of system for leaks.

Badly worn pump—Repair or replace pump. Check for problems causing pump wear such as contaminated oil.

Restriction in suction line—Suction line could be dirty or have inner walls that are collapsing to cut off oil supply. Clean or replace suction line.

Oil leaks in pressure lines—Tighten fittings or replace defective lines.

OVERHEATING OF OIL IN SYSTEM

Using incorrect oil—See specifications on proper oil.

Low oil level—Fill reservoir. Look for leaks.

Engine running too fast—Reduce throttle.

Restriction in hydraulic line—Clean or replace.

Controls stuck in partially or full open position—Free both handles so they return to neutral.

FOAMING OF OIL IN SYSTEM

Low oil level—Fill reservoir. Look for leaks.

Water in oil—Drain and replace oil.

Wrong kind of oil being used—See specifications on proper oil.

Air leak in line from reservoir to pump—Tighten or replace suction line.

Kink in oil suction line—Replace oil line.

Worn seal around pump shaft—Clean sealing area and replace seal. Check oil for contamination

PUMP MAKES NOISE

Low oil level—Fill reservoir. Check system for leaks.

Oil viscosity too high—See specifications on proper oil.

Cold oil—Allow oil to warm up by operating controls slowly under light load.

Suction line plugged or pinched—Clean or replace line between reservoir and pump.

Reservoir air vent plugged—Remove vent plug, flush, and clean air vent.

Air in oil—Tighten or replace suction line. Check system for leaks. Check pump shaft seal.

Worn or scored pump bearings or shafts—Replace pump.

PUMP LEAKS OIL

Damaged seal around pump shaft—Replace seal.

LOAD DROPS WITH CONTROL VALVE IN NEUTRAL POSITION

Leaking or broken oil lines from control valves to cylinder—Check for leaks. Tighten or replace lines.

Oil leaking past cylinder packing or "O" rings—Replace worn parts. If wear is caused by contamination, clean hydraulic system and determine source of dirt.

Oil leaking past control valve—Clean or replace valve. Wear may be caused by contamination. Clean system and determine source of dirt.

CONTROL VALVE STICKS OR WORKS HARD

Valve broken or scored internally—Replace valve.

CONTROL VALVE LEAKS OIL

Worn or damaged "O" rings—Replace "O" rings. If contamination has caused "O" rings to wear, clean system and look for source.

Broken valve parts—Replace parts or valve.

CYLINDER LEAKS OIL

Damaged cylinder bowl—Replace cylinder. Correct cause of damage.

Rod seal leaking—Replace seal. If contamination caused seal to wear, look for source. Wear may be caused by external as well as internal contaminants. Check piston rod for scratches or misalignment.

Loose parts—Tighten parts.

Piston rod damaged—Check rod for nicks or scratches that could cause seal damage or allow oil leakage. Replace defective cylinder.

REPAIR PARTS - MAIN FRAME ASSEMBLY

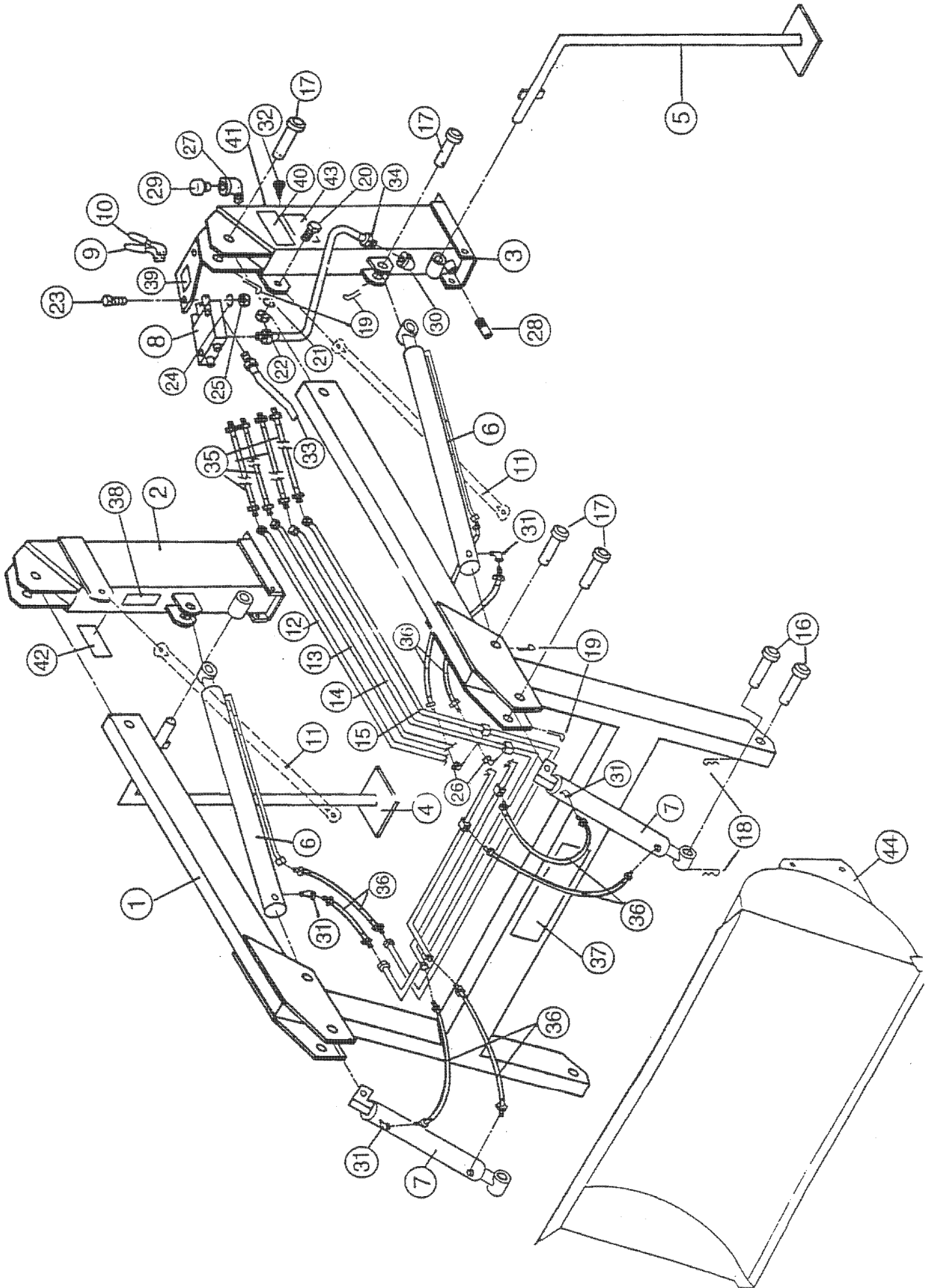

REPAIR PARTS – MAIN FRAME ASSEMBLY

REFERANCE NUMBER	DESCRIPTION	PART NUMBER	NUMBER REQUIRED
1	MAINFRAME w / FEEDLINES	12287	1
2	UPRIGHT - RH	13471	1
3	UPRIGHT - LH	13472	1
4	STAND - RH	12229-1	1
5	STAND - LH	12229-2	1
6	LIFT CYLINDER	102187	2
7	BUCKET CYLINDER	102188	2
8	VALVE	103000	1
9	VALVE HANDLE PKG - RH	13400	1
10	VALVE HANDLE PKG - LH	16005	1
11	BRACE ARM	SEE FRONT MOUNT FOR P/N	2
12	FEEDLINE	100905	1
13	FEEDLINE	100906	1
14	FEEDLINE	100907	1
15	FEEDLINE	100908	1
16	3/4 x 3 HITCH PIN	100243	4
17	3/4 x 2 1/2 HITCH PIN	100898	8
18	#11 CLIP PIN	100172	4
19	5/32 x 1 COTTER PIN	100965	8
20	1/2 -13 x 1 1/2 HEX HD. CAPSCREW	100057	2
21	1/2 LOCKWASHER	100076	2
22	1/2-13 HEX NUT	100087	2
23	1/4-20 x 2 HEX HD. CAPSCREW	100022	2
24	1/4 LOCKWASHER	100072	2
25	1/4-20 HEX NUT	100083	2
26	9/16-18 ORB SWIVEL NUT 90° ELBOW	100900	2
27	1/2 x 90° ST. ELBOW	100115	1
28	1/2 PIPE END	100120	1
29	1/2 VENT PLUG	102114	1
30	3/8 x 90° ST. ELBOW	100108	1
31	1/4 x 90° ST. ELBOW	100103	4
32	#10 x 1/2 HEX HD SELF-TAP SCREW	100314	1
33	3/8 x 52 HYD. HOSE 9/16-18 ORB x 3/8 MS	SEE FRONT MOUNT FOR P/N	1
34	3/8 x 20 HYD. HOSE 9/16-18 ORB x 3/8 MS	101216	1
35	1/4 x 24 HYD. HOSE 9/16-18 ORB x 3/8 MJIC	101217	4
36	1/4 x 16 HYD. HOSE 1/4 MS x 3/8 MJIC	100563	8
37	DECAL - KWIK WAY	101091	1
38	DECAL - MODEL & SERIAL NUMBER	100419	1
39	DECAL - LOADER INSTRUCTION	101203	1
40	DECAL - WARNING	102039	1
41	DECAL - WARNING	102045	1
42	DECAL - WARNING	102046	1
43	DECAL - NOTICE	102048	1
44	40" BUCKET	17325	1

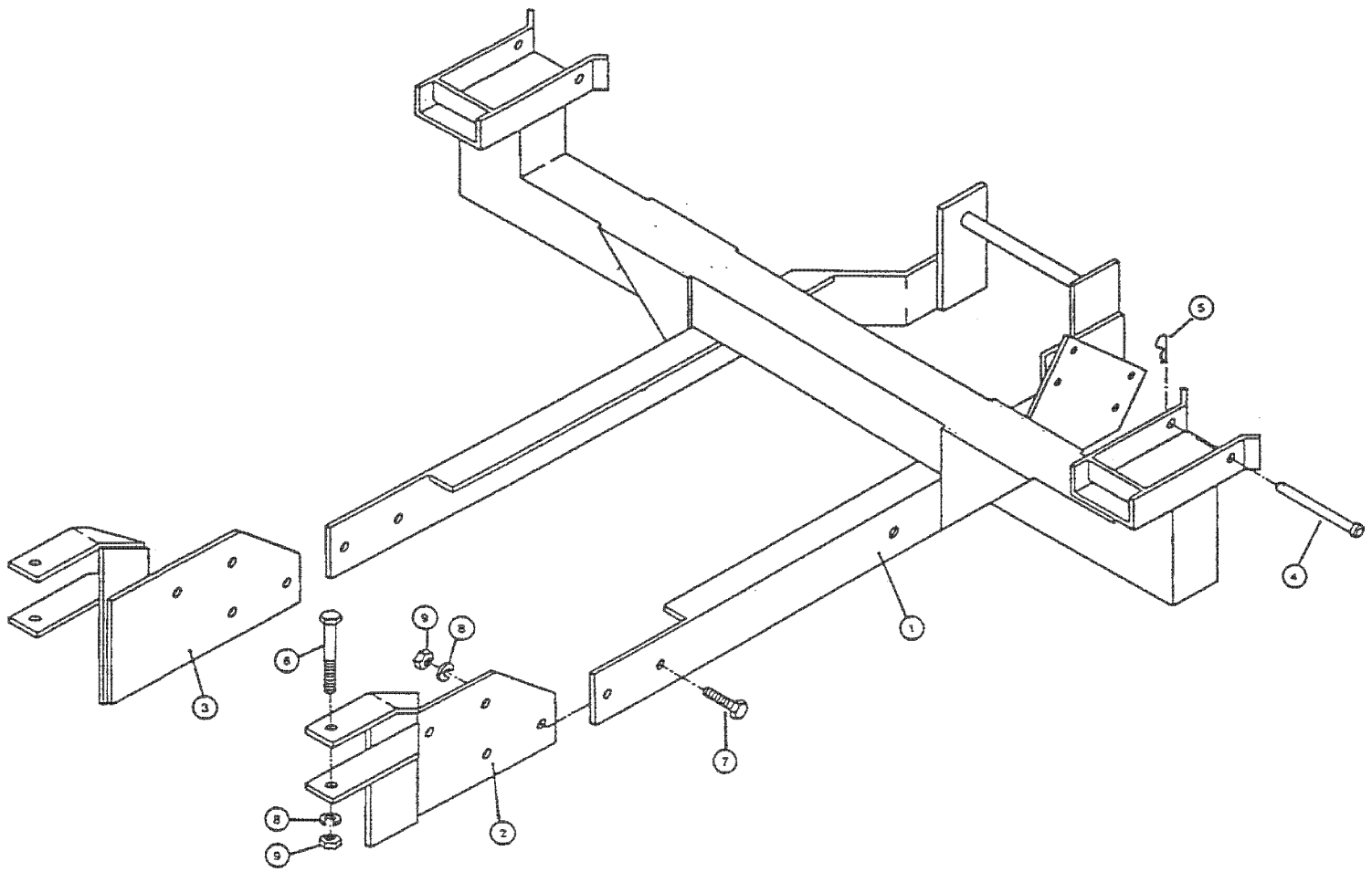

REPAIR PARTS — SUB-FRAME

REFERENCE NUMBER	DESCRIPTION	PART NUMBER	NUMBER REQUIRED
1	SUB-FRAME	13768	1
2	AXLE BRACKET — R.H.	13779-1	1
3	AXLE BRACKET — L.H.	13779-2	1
4	½ x 4½ HITCH PIN	100894	2
5	#3 CLIP PIN	100171	2
6	½ — 13 x 3½ HEX HD. CAPSCREW	100061	2
7	½ — 13 x 1½ HEX HD. CAPSCREW	100057	4
8	½ LOCKWASHER	100076	6
9	½ — 13 HEX NUT	100087	6

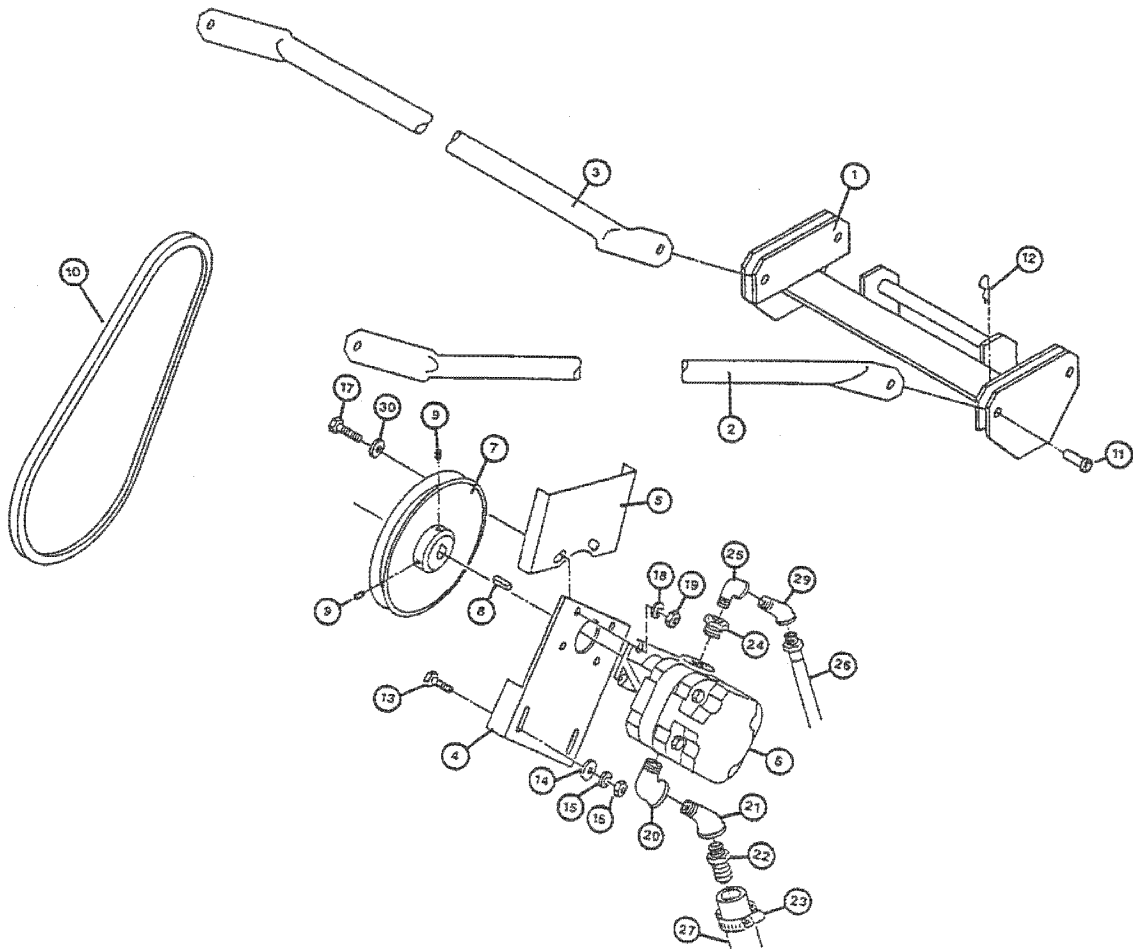

REPAIR PARTS — FRONT MOUNT

REFERENCE NUMBER	DESCRIPTION	PART NUMBER	NUMBER REQUIRED
1	FRONT MOUNT	13760	1
2	BRACE ARM — R.H.	13754-1	1
3	BRACE ARM — L.H.	13754-2	1
4	PUMP PLATE	13756	1
5	BELT GUARD	13759	1
6	304 PUMP	100943	1
7	4 1/2 O.D. x 5/8 BORE V-BELT PULLEY	102448	1
8	3/16 x 3/16 x 1 SQ. KEY	100383	1
9	5/16 — 18 x 1/2 SET SCREW	100910	2
10	32" "B" SECTION V-BELT	101903	1
11	1/2 x 1 1/4 HITCH PIN	100893	2
12	#3 CLIP PIN	100171	2
13	3/8 — 16 x 1 1/4 HEX HD. CAPSCREW	100046	2
14	3/8 FLATWASHER	100079	2
15	3/8 LOCKWASHER	100074	2
16	3/8 — 16 HEX NUT	100085	2
17	5/16 — 18 x 1 1/4 HEX HD. CAPSCREW	100041	4
18	5/16 LOCKWASHER	100073	4
19	5/16 — 18 HEX NUT	100084	4
20	1/2 x 90° ST. ELBOW	100115	1
21	1/2 x 45° ST. ELBOW	100117	1
22	1/2 PIPE END	100120	1
23	#16 HOSE CLAMP	100138	2
24	1/2 — 3/8 HEX RED. BUSHING	100200	1
25	3/8 x 90° ST. ELBOW	100108	1
26	3/8 x 52 HYD. HOSE 3/8 MS x 9/16 — 18 ORB M	101209	1
27	3/4" SUCTION HOSE x 40"	17826	1
28	NYLON TIES (NOT SHOWN)	100257	4
29	3/8 X 45° ST. ELBOW	100109	1
30	1/4 FLATWASHER	100435	2

HYDRAULIC VALVE ASSEMBLY

COMPLETE WITH HANDLES

INLET PORT VALVE P/N 103000

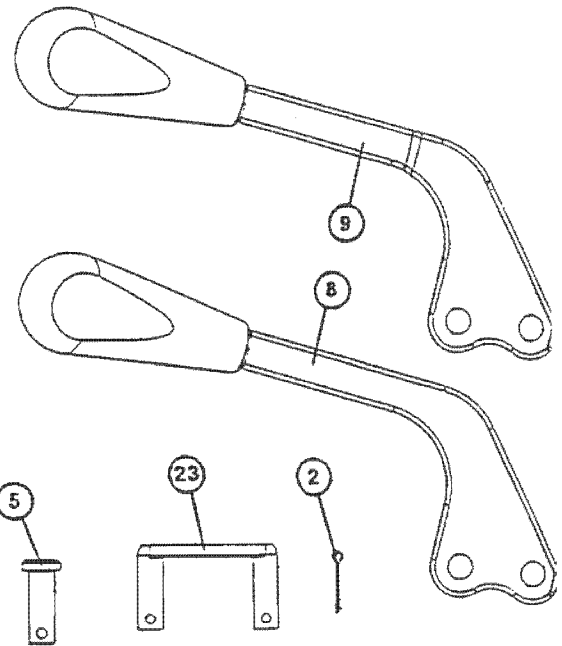
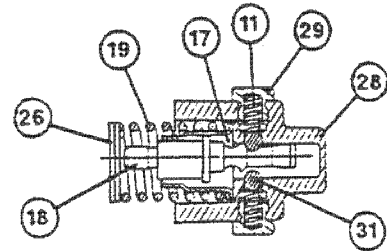
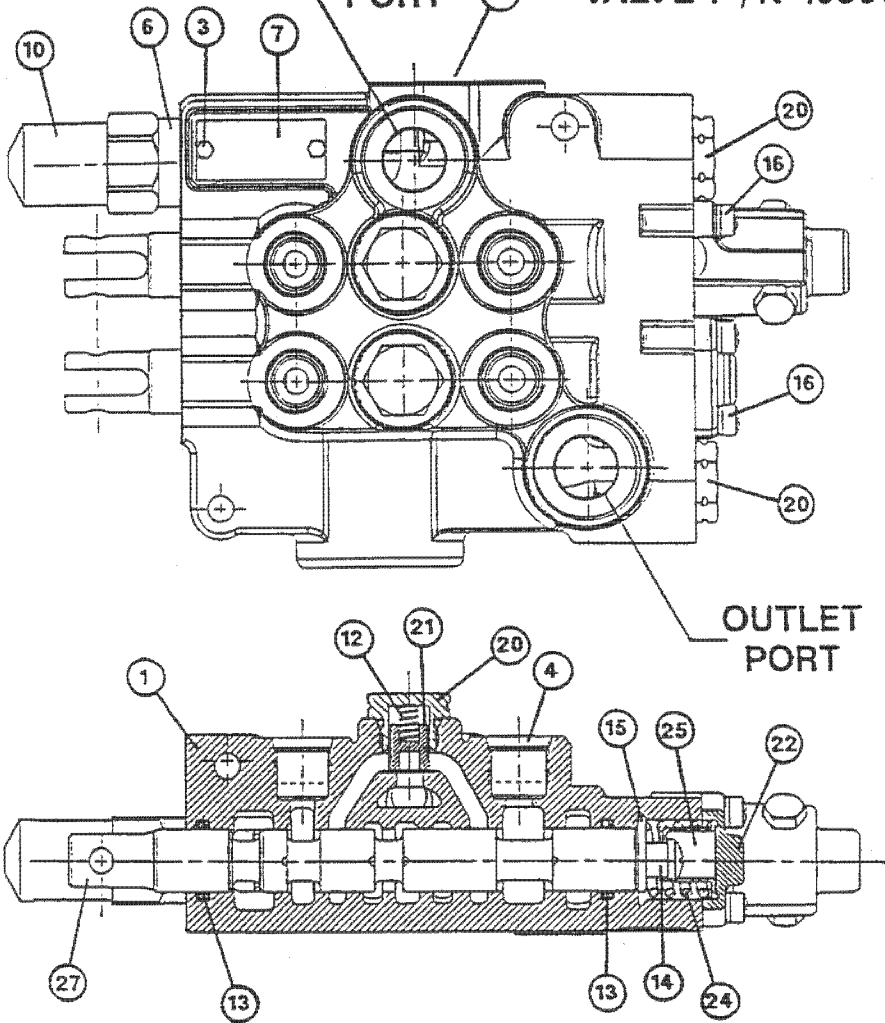

HYDRAULIC VALVE REPAIR KITS

ITEMS 1 AND 27 ARE A MATCHED SET AND CANNOT BE OBTAINED SEPERATELY.

SEAL KIT, P/N 101161, CONTAINS 4 OF ITEM 13.

LOAD CHECK KIT, P/N 101121, CONTAINS 2 OF ITEMS 12, 20, AND 21.

DETENT FLOAT KIT, P/N 101200, CONTAINS 1 OF ITEMS 17, 18, 19, AND 28. 2 OF ITEMS 11, 26, 29, AND 31.

SPRING CENTERING KIT, P/N 101199, CONTAINS 1 OF ITEMS 14, 15, 22, 24, AND 25. 2 OF ITEM 16.

RELIEF VALVE KIT, P/N 103011, CONTAINS 1 OF ITEM 6.

STRAIGHT HANDLE KIT, P/N 13400, CONTAINS 1 OF ITEMS 5, 8, AND 23. 3 OF ITEM 2.

L.H. HANDLE KIT, P/N 16005, CONTAINS 1 OF ITEMS 5, 9, AND 23. 3 OF ITEM 2.

HYDRAULIC VALVE REPAIR PARTS

VALVE P/N 103000

REFERENCE NUMBER	DESCRIPTION	PART NUMBER	NUMBER REQUIRED
1	BODY		1
2	COTTER PIN	101399	6
3	SCREW		2
4	SHIPPING PLUG		6
5	CLEVIS PIN	101189	2
6	RELIEF VALVE	103014	1
7	NAME PLATE		1
8	HANDLE	101187	1
9	HANDLE-L.H.	101834	1
10	TAMPER PROOF CAP	103012	1
11	DETENT SPRING	101174	2
12	LOAD CHECK SPRING	101179	2
13	O-RING	101163	4
14	MACHINE SCREW	101164	1
15	WASHER	101168	1
16	SCREW W/LOCKWASHER	101169	4
17	SPACER	101170	1
18	DETENT FLOAT SPOOL	101171	1
19	RETURN SPRING	101172	1
20	LOAD CHECK PLUG ASSY	101178	4
21	LOAD CHECK POPPET	101177	2
22	END CAP	101165	1
23	C-HOOK	101188	2
24	SPRING	101166	1
25	SPACER	101167	1
26	WASHER	101168	2
27	SPOOL		2
28	DETENT END CAP	101176	1
29	DETENT PLUG	101173	2
30	PLUG	103013	1
31	BALL	101175	2

HYDRAULIC CYLINDER ASSEMBLY AND REPAIR PARTS

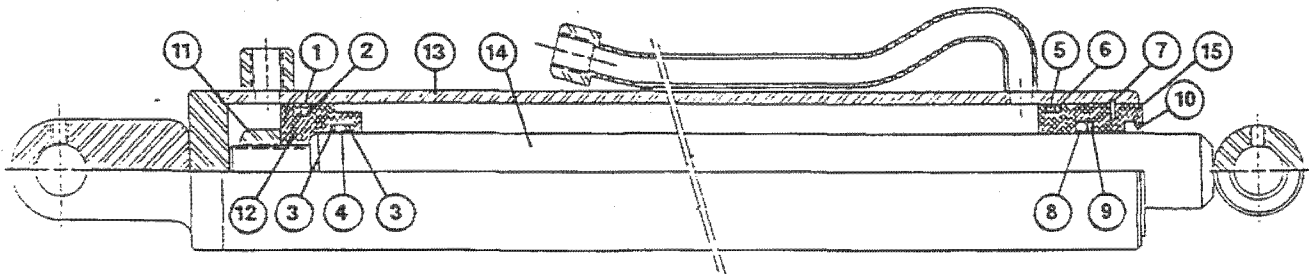

CYLINDER P/N 102187

REFERENCE NUMBER	DESCRIPTION	PART NUMBER	NUMBER REQUIRED
1	PISTON RING	102190	1
2	O-RING	102191	1
3	BACK-UP	102192	2
4	O-RING	102193	1
5	O-RING	102194	1
6	BACK-UP	102195	1
7	SNAP RING	102196	1
8	O-RING	102197	1
9	BACK-UP	102198	1
10	WIPER	102199	1
11	3/4-16 LOCKNUT	102206	1
12	PISTON	102200	1
13	BARREL	102201	1
14	ROD	102202	1
15	HEADGLAND	102203	1

ITEMS 1 THRU 10, IN QUANTITIES SHOWN
ARE INCLUDED IN SEAL KIT P/N 102189.
THESE ITEMS ARE NOT AVAILABLE SEPARATELY.

CYLINDER DIA.	2
ROD DIA.	1 1/8
STROKE	16 1/2
RETRACTED LENGTH	24 1/2
EXTENDED LENGTH	41

HYDRAULIC CYLINDER ASSEMBLY AND REPAIR PARTS

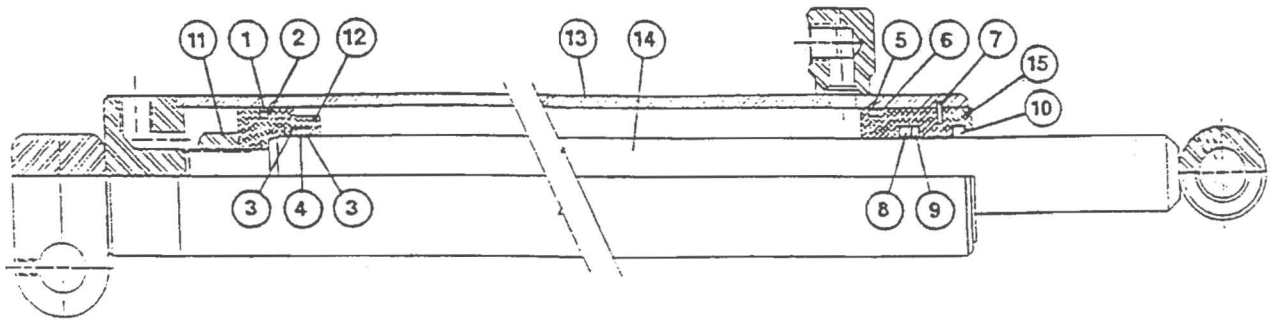

CYLINDER P/N 102188

REFERENCE NUMBER	DESCRIPTION	PART NUMBER	NUMBER REQUIRED
1	PISTON RING	102190	1
2	O-RING	102191	1
3	BACK-UP	102192	2
4	O-RING	102193	1
5	O-RING	102194	1
6	BACK-UP	102195	1
7	SNAP RING	102196	1
8	O-RING	102197	1
9	BACK-UP	102198	1
10	WIPER	102199	1
11	3/4-16 LOCKNUT	102206	1
12	PISTON	102200	1
13	BARREL	102204	1
14	ROD	102205	1
15	HEADGLAND	102203	1

ITEMS 1 THRU 10, IN QUANTITIES SHOWN
 ARE INCLUDED IN SEAL KIT P/N 102189.
 THESE ITEMS ARE NOT AVAILABLE SEPARATELY.

CYLINDER DIA.	2
ROD DIA.	1 1/8
STROKE	11
RETRACTED LENGTH	20 1/2
EXTENDED LENGTH	31 1/2